

# GX 690

*Horizontal shaft gasoline (petrol) engine*



*Moteur à essence à arbre de prise de force horizontal*

*Benzinmotor mit horizontaler Kurbelwelle*

*Motore a benzina ad albero orizzontale*

*Bensinmotor med horisontell axel*

*Benzinmotor met horizontale uitgaande as*

# GX 690

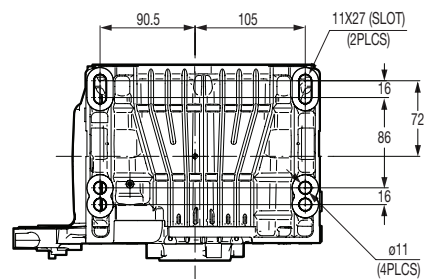
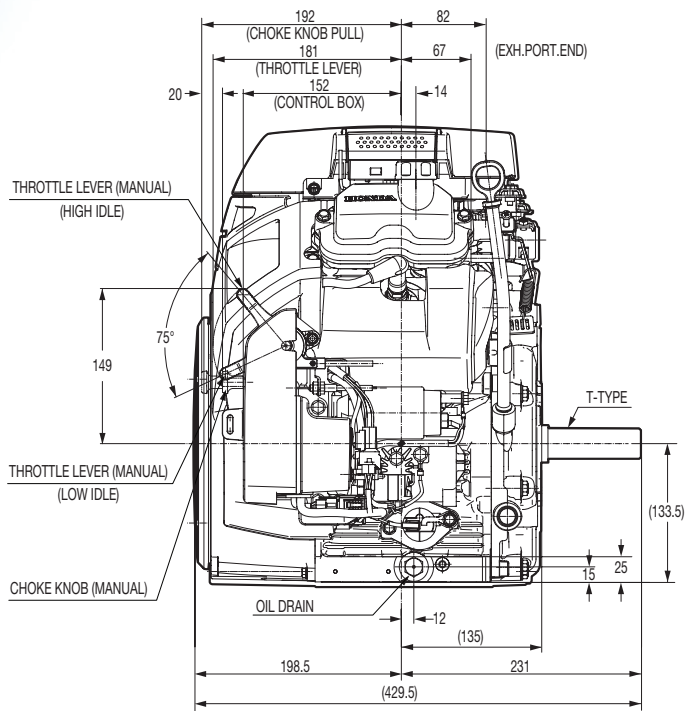
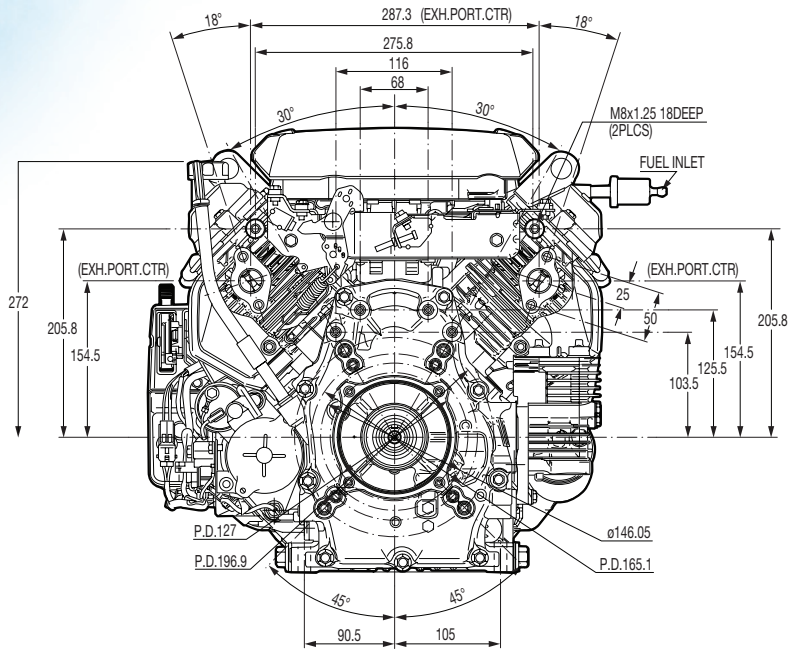
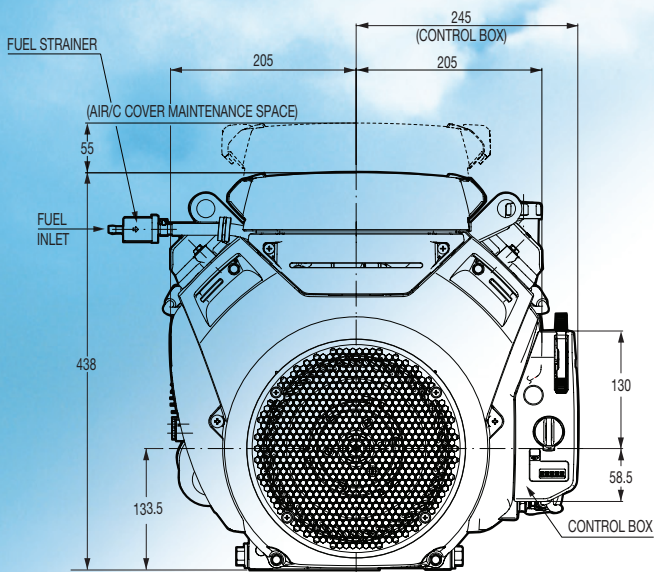



## Dimensions Unit: mm (in.)

### STANDARD TYPE

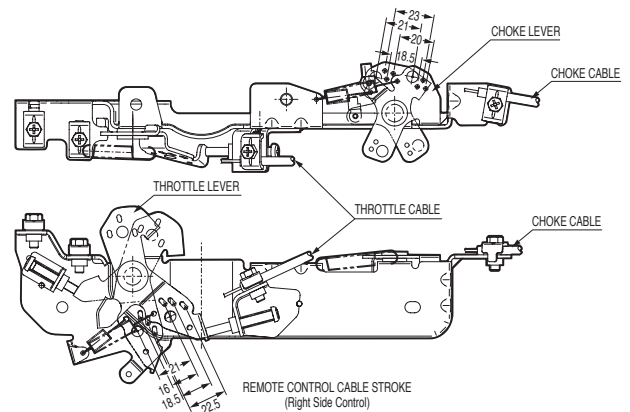
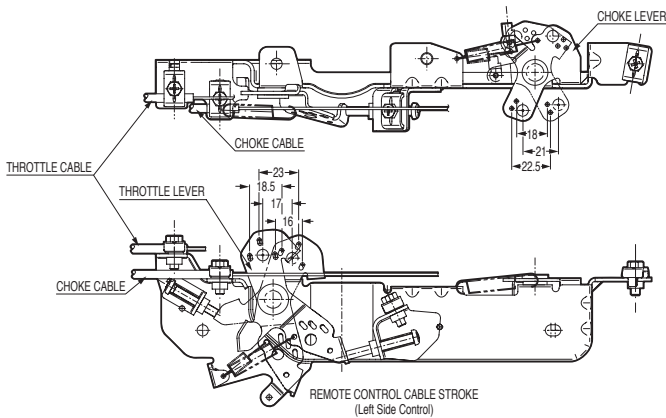

## PTO SHAFT DIMENSIONS

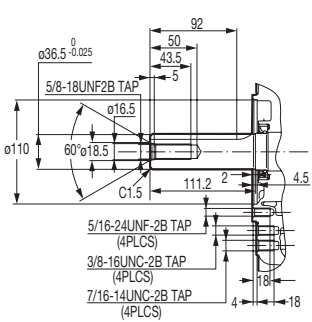
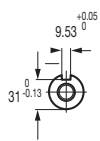

**B-TYPE**

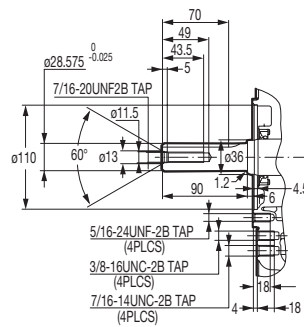
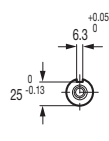

**T-TYPE**

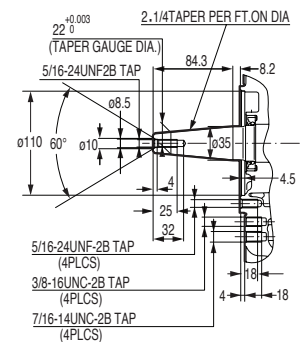

**V-TYPE**

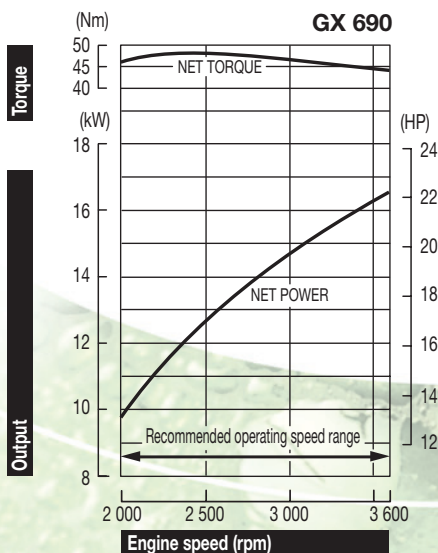

The power rating of the engine indicated in this document is the net power tested on a production engine for the engine model and measured in accordance with SAE J1349 at a specified rpm. Mass production engines may vary from this value. Actual power output for the engine installed in the final machine will vary depending on numerous factors, including the operating speed of the engine in application, environmental conditions, maintenance, and other variables.

La potenza indicata in questo documento, è la potenza netta rilevata su questo modello di motore in fase di produzione, ed è stata misurata secondo la procedura SAE J1349 ad un numero di giri specifico. Nella produzione di massa si possono riscontrare variazioni rispetto a questi valori. La potenza del motore installato nella macchina può dipendere da numerosi fattori, incluso il numero di giri al quale il motore è impiegato, le condizioni ambientali, dal livello di manutenzione ed altre variabili.

La puissance du moteur indiquée dans ce document est une puissance nette obtenue par l'essai d'un moteur de série selon la norme SAE J 1349 à une vitesse de rotation donnée. La puissance d'un autre moteur de production peut être différente de cette valeur indiquée. La puissance réelle d'un moteur installé sur une machine dépendra de différents facteurs comme la vitesse de rotation, les conditions de température, d'humidité, de pression atmosphérique, de maintenance et autres.

De bepaling van het vermogen van de motor, vermeld in dit document, is het netto vermogen getest op een productiemotor en gemeten in overeenstemming met SAE J1349 aan een specifieke t/min. Motoren van massaproductie kunnen van deze waarde variëren. Het werkelijke vermogen van de geïnstalleerde motor in het eindproduct kan afwijken, afhankelijk van talrijke factoren, zoals de operationele snelheid van de motor in een applicatie, omgevingsfactoren, onderhoud en andere variabelen.

Die Leistungsangabe der in diesem Dokument aufgeführten Motoren ist die Netto-Leistung gemäß SAE J1349, getestet bei einer definierten Drehzahl an einem Produktionsmotor. Bei Motoren aus Serienproduktion kann der Wert abweichen. Die Leistungsabgabe in einem Fertigerät weicht, bedingt durch unterschiedliche Faktoren, wie Motordrehzahl in der Applikation, Umwelteinflüsse, Grad der Instandhaltung und andere Einflüsse ab.

Den i detta dokument nämnda motors effekt, är uppmätt i netto effekt. I enlighet med mätmetoden SAE J1349. Massproducerade motorer kan avvika från nämnda värde. Den faktiska effekten för varje motor kan variera beroende på bl a. varvtal, yttre omgivningar, underhåll, typ av applikation, mm.



## Specifications

Model GX 690	
Engine type	Air cooled 4-stroke OHV petrol engine, 90° V-twin design, horizontal shaft
Bore x stroke	2 / 78 x 72 mm
Displacement	688 cm <sup>3</sup>
Compression ratio	9.3 : 1
Net power	16.6 kW (22.3 HP) / 3600 rpm
Cont. rated power	11.5 kW (15.4 HP) / 3000 rpm 13.0 kW (17.4 HP) / 3600 rpm
Max. net torque	48.3 Nm / 4.93 kgfm / 2500 rpm
Ignition system	Digital CDI with variable ignition timing
Carburetor	2-barrel carburetor, fuel cut solenoid
Lubrication	Full-pressure
Starting system	Electric starter
Fuel cons. at rated power	6.2 L/hr - 3600 rpm
Engine oil capacity	1.9 l
Dimensions (L x W x H)	429 x 410 x 438 mm (T-Type)
Dry weight	44.6 kg

## Spezifikationen

Modell GX 690	
Motortyp	Luftgekühlter 2-Zylinder 4-Takt OHV Benzinmotor, 90° V-Twin, horizontale Kurbelwelle
Bohrung x Hub	2 / 78 x 72 mm
Hubraum	688 cm <sup>3</sup>
Verdichtung	9.3 : 1
Netto-Leistung	16.6 kW (22.3 HP) / 3 600 min <sup>-1</sup>
Max. Dauerleistung	11.5 kW (15.4 HP) / 3 000 min <sup>-1</sup> 13.0 kW (17.4 HP) / 3 600 min <sup>-1</sup>
Max. Netto-Drehmoment	48.3 Nm / 4.93 kgfm / 2 500 min <sup>-1</sup>
Zündung	Digitale CDI-Zündung mit variabler Zündeneinstellung
Vergaser	Doppelvergaser, Magnetventil
Schmierung	Volldruck
Starter	Elektrostart
Benzinverbrauch bei Dauerleistung	6.2 L/h - 3 600 min <sup>-1</sup>
Motorölkapazität	1.9 Liter
Maße (L x B x H)	429 x 410 x 438 mm (T-Typ)
Trockengewicht	44.6 kg

## Specificaties

Model GX 690	
Motortype	Luchtgekoelde 4-takt OHV benzinmotor, 90° v-twin, horizontale uitgaande as
Boring x slag	2 / 78 x 72 mm
Cilinderinhoud	688 cm <sup>3</sup>
Compressie	9.3 : 1
Netto vermogen	16.6 kW (22.3 HP) / 3 600 t/min
Continu nominaal vermogen	11.5 kW (15.4 HP) / 3 000 t/min 13.0 kW (17.4 HP) / 3 600 t/min
Max. netto koppel	48.3 Nm / 4.93 kgfm / 2 500 t/min
Ontstekingsstelsel	Digitale CDI met variabel ontstekingsstijdstip
Carburator	Dubbele carburator, brandstofafsluitende elektromagneet
Smering	Voldruk
Startstelsel	Electrische start
Brandstofverbruik aan nominaal vermogen	6.2 l/u - 3 600 t/min
Motoroliecapaciteit	1.9 Liter
Afmetingen (L x B x H)	429 x 410 x 438 mm (T-Type)
Doorgewicht	44.6 kg

## Spécifications techniques

Modèle GX 690	
Type du moteur	Moteur à essence bicylindre 4 temps OHV, refroidissement à air, cyl. en V à 90°, arbre de prise de force horizontal, cyl. chemisé en fonte
Alésage x course	2 / 78 x 72 mm
Cylindrée	688 cm <sup>3</sup>
Taux de compression	9.3 : 1
Puissance nette	16.6 kW (22.3 HP) / 3 600 tr/mn
Puissance en service continu	11.5 kW (15.4 HP) / 3 000 tr/mn 13.0 kW (17.4 HP) / 3 600 tr/mn
Couple maximum	48.3 Nm / 4.93 kgfm / 2 500 tr/mn
Système d'allumage	Allumage digital CDI avec avance variable
Carburateur	Carburateur double corps avec électrovanne de coupure de carburant
Lubrification	Sous pression d'huile
Système de démarrage	Démarreur électrique
Consommation de carburant en service continu	6.2 litre(s)/heure - 3 600 tr/mn
Capacité d'huile moteur	1.9 l
Dimensions (L x l x H)	429 x 410 x 438 mm (Typ-T)
Poids à sec	44.6 kg

## Dati tecnici

Tipo GX 690	
Tipo di motore	Motore bicilindrico OHV ad albero orizzontale ciclo otto, 4 tempi, cilindri disposti a V di 90° raffreddamento ad aria forzata
Alesaggio x corsa	2 / 78 x 72 mm
Cilindrata	688 cm <sup>3</sup>
Rapporto di compressione	9.3 : 1
Potenza netta	16.6 kW (22.3 HP) / 3 600 giri/min
Potenza nominale continua	11.5 kW (15.4 HP) / 3 000 giri/min 13.0 kW (17.4 HP) / 3 600 giri/min
Coppia massima	48.3 Nm / 4.93 kgfm / 2 500 giri/min
Impianto di accensione	Digital CDI con anticipo accensione variabile
Carburatore	Carburatore a doppio corpo, solenoide interruzione erogazione carburante
Lubrificazione	Forzata
Avviamento	Elettrico
Consumo combustibile alla potenza nominale	6.2 Litri/ora - 3 600 giri/min
Capacità coppa olio	1.9 Litri
Dimensioni (Lu x La x A)	429 x 410 x 438 mm (T-Tipo)
Peso a secco	44.6 kg

## Specifikationer

Modell GX 690	
Motortyp	Luftkyld 4-takts bensinmotor med överliggande ventiler, 90° V-twin design, Horizontal axel
Cylinderdiameter x slaglängd	2 / 78 x 72 mm
Slagvolym	688 cm <sup>3</sup>
Kompressionsförhållande	9.3 : 1
Netto effekt	16.6 kW (22.3 HP) / 3 600 varv per minut
Rek. kontinuerlig effekt	11.5 kW (15.4 HP) / 3 000 varv per minut 13.0 kW (17.4 HP) / 3 600 varv per minut
Max. netto vridmoment	48.3 Nm / 4.93 kgfm / 2 500 varv per minut
Tändsystem	Digitalstyrt elektroniskt tändsystem, CDI
Förgasare	2 ports förgasare, bränslesolenoid
Smörjning	Fullt tryck
Startsystem	Elektrisk start
Bränsleförbrukning vid märkeffekt	6.2 L/tim - 3 600 varv per minut
Oljevolym	1.9 Liter
Dimensioner (L x B x H)	429 x 410 x 438 mm (T-Typ)
Torrsvikt	44.6 kg

# HONDA

## ENGINES

**Honda Europe NV**  
EUROPEAN ENGINE CENTER  
Langerbruggestraat 104  
B-9000 Gent  
TEL: + 32 (0)9 250 12 11  
FAX: + 32 (0)9 250 14 24

[www.honda-engines-eu.com](http://www.honda-engines-eu.com)

## Honda Engines - France

Honda Motor Europe (South) S.A. • Parc d'Activités de Pariest • Allée du 1<sup>er</sup> Mai, BP 46 • Croissy Beaubourg • F-77312 Marne-la-Vallée Cedex 2  
TEL: + 33 (0)1 60 37 30 16 • FAX: + 33 (0)1 60 37 33 66

## Honda Engines - Germany

Honda Motor Europe (North) GmbH • Spremlinger Landstraße 166 • D-63069 Offenbach/Main  
TEL: + 49 (0)6 98 30 93 65 • FAX: + 49 (0)6 98 30 91 28

## Honda Engines - Italy

Honda Logistic Centre Italy S.p.A. • Via Strà 153-154 • I-37030 Colognola ai Colli (VR)  
TEL: + 39 045 6173341 • FAX: + 39 045 6151270

## Honda Engines - Sweden

Honda Logistics Center Sweden AB • Box 50583 Västgustavägen 17 • SE-20215 Malmö  
TEL: + 46 40 38 07 00 • FAX: + 46 40 38 07 88

## Honda Engines - United Kingdom

Honda Logistics Centre (UK) Ltd. • Viscourt Way, South Marston Park • Swindon SN3 4TN, UK  
TEL: + 44 (0)1 455 559429 • FAX: + 44 (0)1 455 559428

All specifications are subject to change without notice.  
Les caractéristiques techniques peuvent être modifiées à tout moment et sans préavis.  
Spesifikationer kan ändras utan föregående meddelande.

Le specifiche sono soggette a cambiamento senza preavviso.  
Die Spezifikationen können ohne Vorankündigung geändert werden.  
Alle technische specificaties kunnen op elk ogenblik en zonder kennisgeving gewijzigd worden.

Ref. EEC - TS 2009/4 - GX 690

© www.honda.com